

› **PRIVACY BY DESIGN IN ENERGY**

ECP-PI.lab PbD III | Marc van Lieshout



TNO innovation
for life

PI-LAB

- **Collaboration between:**
 - Radboud University – ICIS
 - Tilburg University – TILT
 - TNO – Networked Information



SMART METER: DATA COLLECTION

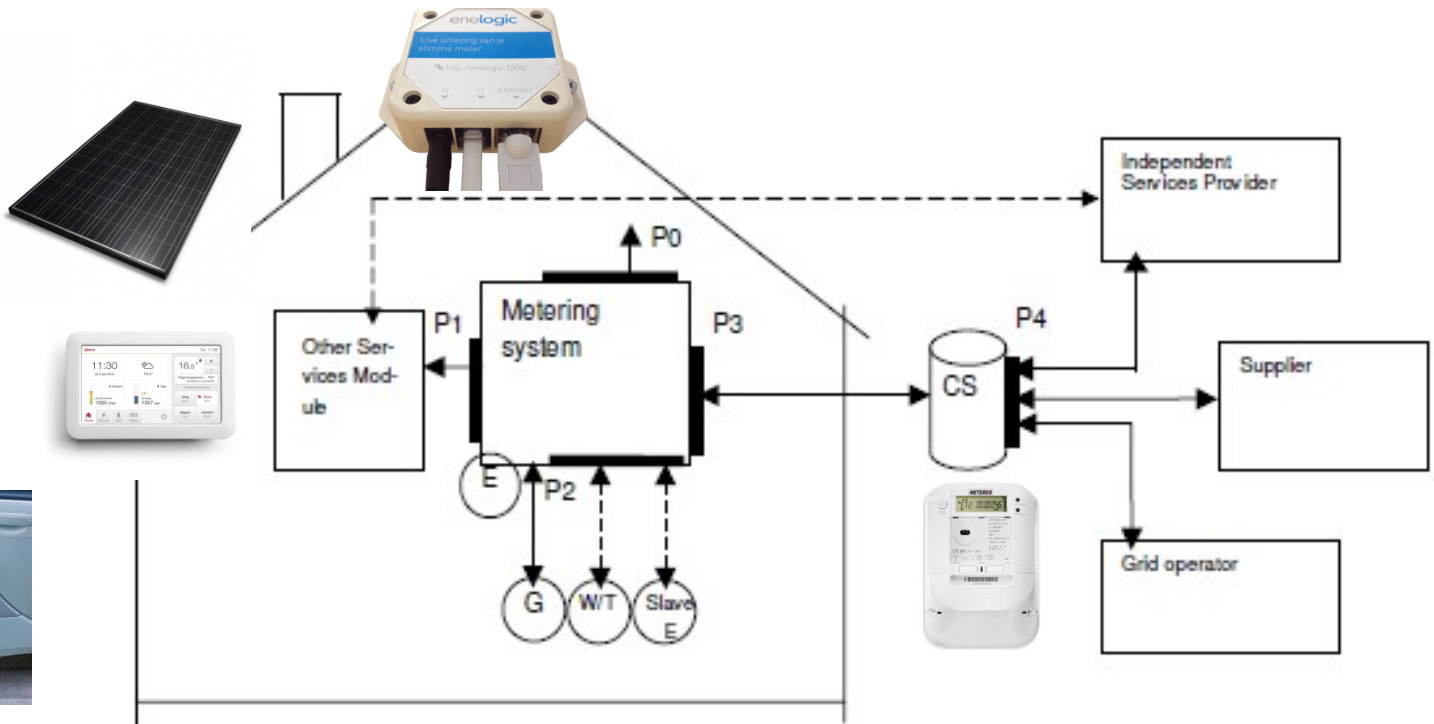

SMART METER: 'FLY ON THE WALL'?

The smart meter as surveillance instrument



Smart meters - Opt out by paying?

MANIFESTATION

Organisée par Collectif Stop Linky
BORDEAUX

SAMEDI 10 JUIN 2017
départ à 15h, Place de la Victoire

**Dites NON ! aux compteurs
communicants LINKY**

- ✓ absence de concertation avec le public
- ✓ pas de réel bénéfice pour les usagers
- ✓ intrusion dans notre vie privée
- ✓ risques pour notre santé
- ✓ poses forcées de compteur, pannes...

Pour en savoir plus :
stoplinky.bordeauxmetropole@gmail.com

SMART METER: ATTITUDES

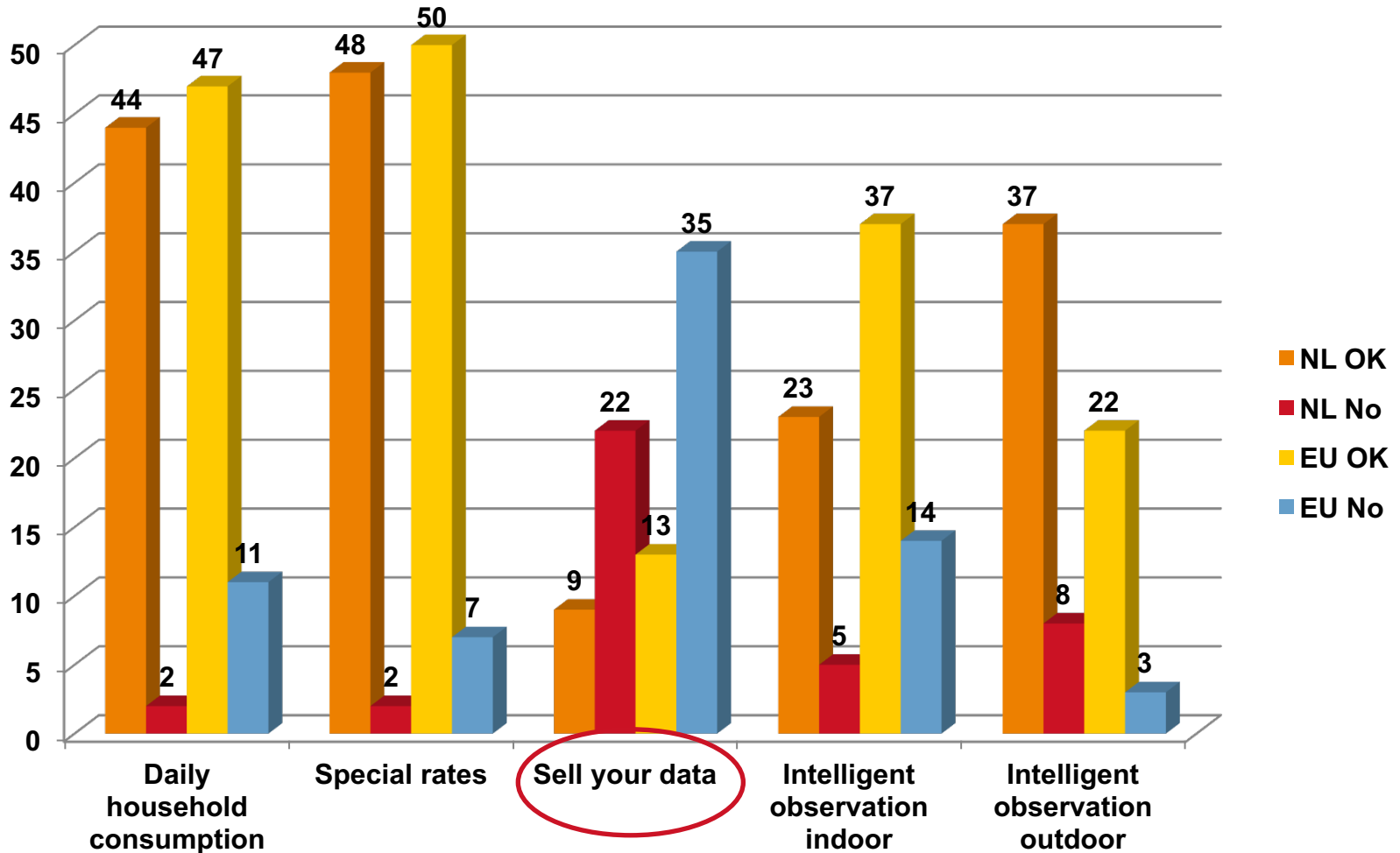

DATA-ECOSYSTEM IN ENERGY

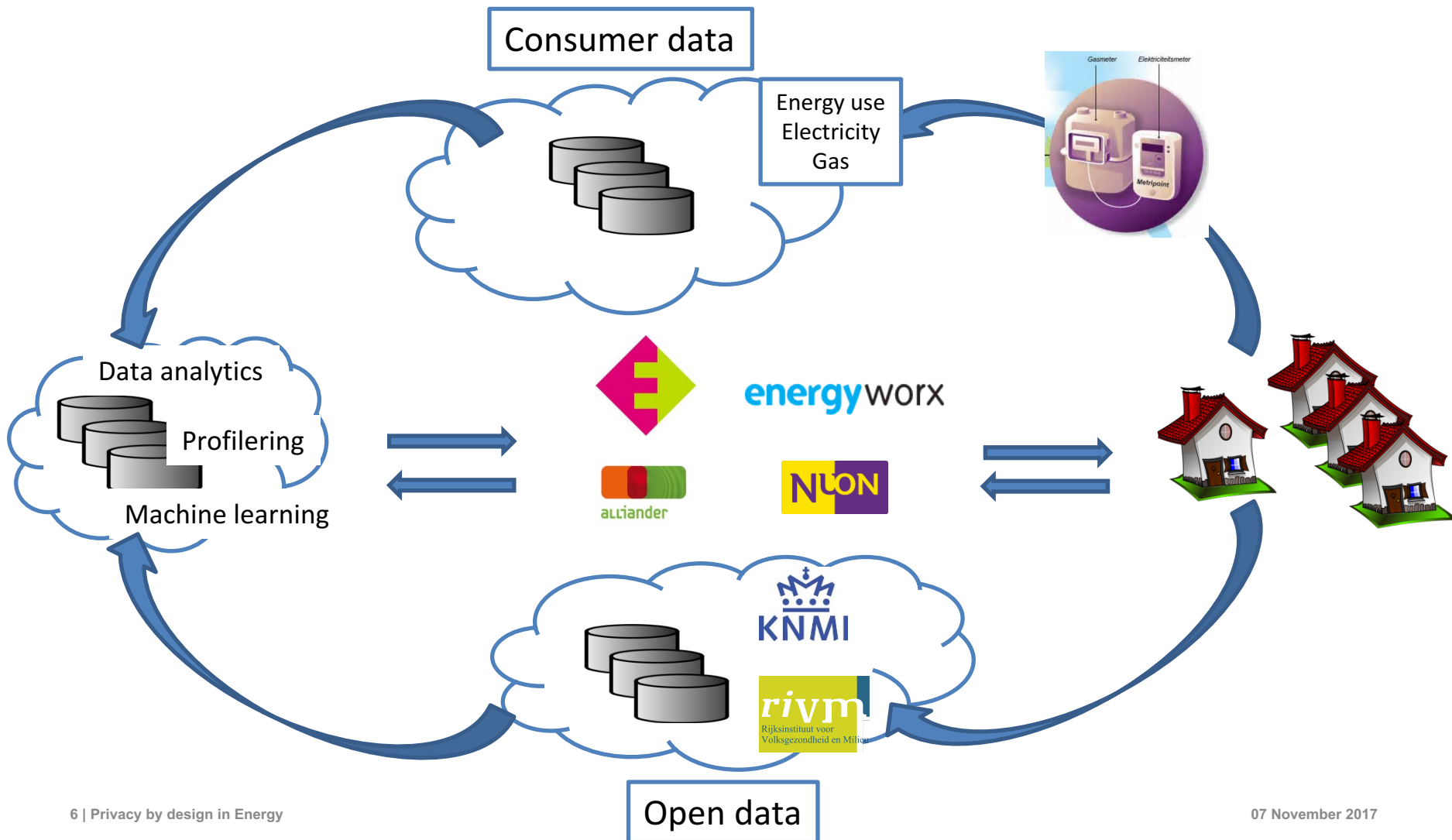

INFORMATION A-SYMMETRY - 1

MOBILE MARKETING velti, mobivity, bango, netbiscuits, admob, hipcricket, iLoop mobile, Localytics	MOBILE APPS Urban Airship, MOBILEFRAME, brightpress, Kontagent	GAMING/FACEBOOK APPS gigya, Badgeville, BIGDOOR	CREATIVE TOOLS balsamiq, MockFlow, Adobe, BO.LT, visual.ly	DIGITAL ASSET MANAGEMENT ThirdLight, CELUM, saepi, Canto, WIDEN
TARGETING bluekai, brilig, bizo, exelate, quxntcast, netmining	DISPLAY AD MANAGEMENT DataXu, ADCHEMY, TURN, TRIGGIT, Microsoft Advertising	E-COMMERCE shopify, gsi commerce, demandware, Magento, marketlive, INTERSHOP, iCongo, ZOOPY, goeCart, hybris, Digital River, atg	PERSONALIZATION RapLeaf, choice@stream	LOYALTY MANAGEMENT loyalty lab, RatePoint, INCENTIVELOGIC, NextBee
CREATIVE OPTIMIZATION AdReady, TUMRI, affinova	VIDEO AD MANAGEMENT YuMe, TubeMogul, Visible MEASURES	VIRTUAL EVENTS UNISFAIR, webex, citrix, virtualevents365	VIDEO CONTENT Kaltura, brightcove, twistage	APIs apigee, 3scale, WASHERY, LAYER 7
SEARCH AD MANAGEMENT Marin, ClickEquations, Clickable, KENSHOOD, WordStream	SEO TOOLS seo MOZ.org, conductor, COVARIQ, BRIGHT EDGE, RAVEN, GinzaMetrics, optify, altruiK, BloomReach, Wordtracker, searchmetrics, gShifti	CORE WEBSITE Autonomy, sitecore, SDL, IBM WebSphere, Day, Joomla!, Apache, FatWire, Drupal, Clickability	CUSTOM WEB APPS MVC, django, amazon web services, heroku, git	MARKETING AUTOMATION ELQ, Pardot, Infusionsoft, Manticore, Marketo, neolane, demandbase, ClickDimensions, loopfuse
SOCIAL MEDIA AD MANAGEMENT Adaptly, BLINQ MEDIA, adTerror, Alchemy, EfficientFrontier, vurve, epic social	LANDING PAGES & MICROSITES ion INTERACTIVE, unbounce, OnDialog, CrownPeak	BLOGS WordPress, Zemanta, Squarespace, COMPENDIUM, tumblr	COMMUNITIES acqua, NING jive, telligent, inGage NETWORKS, mZinga	EMAIL MARKETING ExactTarget, emma, iContact, silverPOP, Datran Media, Responsys, MailChimp, VerticalResponse, Bronto
SOCIAL MEDIA MARKETING MANAGEMENT lithium, awareness, KickApps, vocus, vitrue, Seismic, ATTENsITY, MessageMaker, moxie, synthesio, edgg, sprinklr, hootsuite, BuzzLabs	WEB TESTING & OPTIMIZATION ion INTERACTIVE, SITESPECT, UserTesting.com, maxymiser, Optimizely, Wingify	CRM ORACLE, salesforce.com, RIGHT NOW, SAP, Microsoft Dynamics, CDC Software, SUGARCRM	SALES AUTOMATION salesforce.com, Steelwedge, Sage SalesLogix	CUSTOM DATABASES mongoDB, PostgreSQL, Microsoft SQL Server, ORACLE MySQL
	BUSINESS INTELLIGENCE sas, SPSS, birst, IBM, pivotlink, TERADATA, hadoop, tableau			

ENERGY AND DATA

Wettelijk kader:

- GDPR (2016)
- Energy efficiency directive (2012)
- Electricity directive (2009)
- Gas directive (2009)

Nederland

- P1 en P4 poort?
- ODAs op P1 poort?
- Rol van netbeheerders?
- Wat is de waarde van energiedata?
- Hoe wordt privacy geborgd?

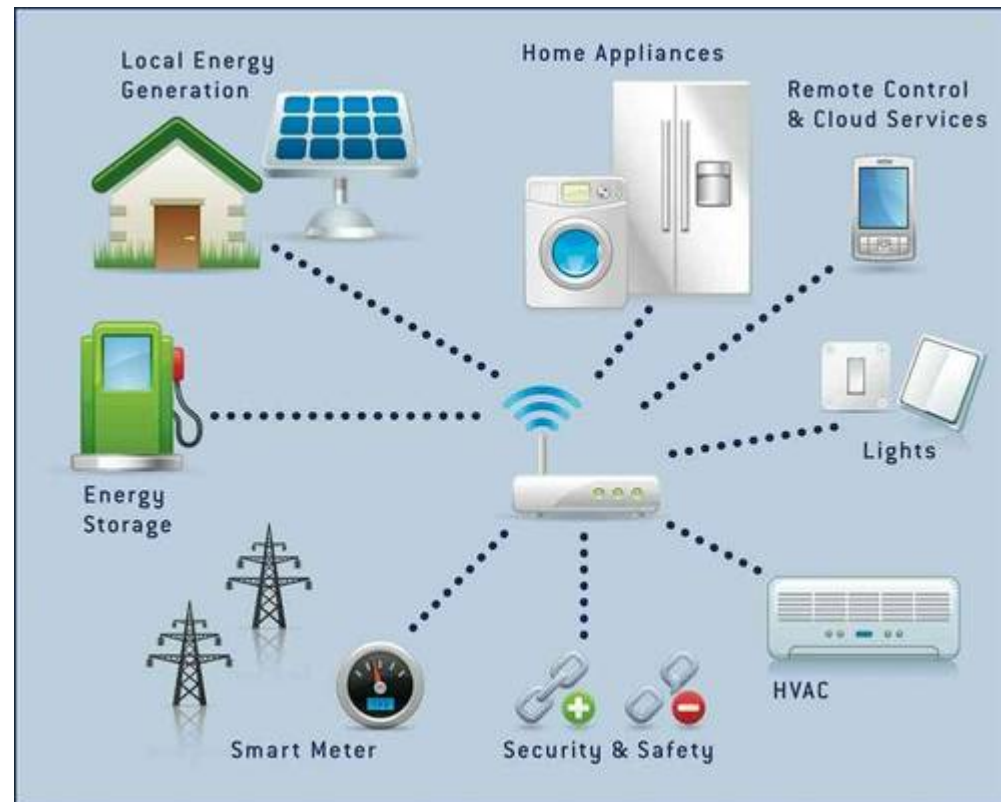

PROGRAMMA

- › 14:00 uur: Inloop
- › 14:30 uur: Welkom door ECP&PI.lab
Esther Mieremet en Marc van Lieshout
- › 14:45 uur: *‘Enexis – hoe is privacy by design toegepast?’*
Boas Bierings (Enexis)
- › 15:15 uur: *‘Tippiq – hoe is privacy in het platform Tippiq als ontwerpkenmerk meegenomen?’*
Bob Kronenburg (Tippiq)
- › 15.45 uur: Discussie
- › 16.15 uur: *‘CIP – Privacy selfassessment / privacy by design handboek’*
Ad Reuijl (CIP, UWV)
- › 16.30 uur: Start borrel

› **THANK YOU FOR YOUR ATTENTION**



TNO innovation
for life

Marc.vanlieshout@tno.nl; 06-51246618

GDPR COUNTDOWN

- › Jaarlijkse PI.lab conferentie
- › 7 December a.s. In de Driehoek, Utrecht (Willemsplantsoen 1C)
- › Keynotes:
 - › Prof.dr. Mireille Hildebrandt (Radboud, VU): Algoritmes en de GDPR
 - › Giovanni Butarelli (EDPS, videoboodschap): GDPR Countdown
 - › Prof. dr Ron Deibert (University of Toronto): 'War in the World Brain
- › Workshops:
 - › Debat over de Wiv
 - › ECP-PI.lab: Actieprogramma Privacy als innovatiekans
 - › Het indexing project
 - › Privacy als cultureel fenomeen

Use button 'Pictures'  to change background

TNO innovation
for life